

Curved magnet, Model 221

Main Characteristics

- portable route measurements
- for side connector sensors with M6 and 1/4" 28 UNF thread
- for flat surfaces only (to be used whenever possible with our magnet targets)
- Stainless steel

Description

The use of magnet bases is convenient and quick for many applications (route measurements). They produce an intimate and stiff contact between DC and few kilohertz. The high frequency response (above few kHz) is significantly distorted. Obviously the machine surface should be magnetically attractive and free of paint chips and scale. Painted surface should use our stainless steel magnet target model 208 that greatly improve the high frequency response. We also recommend the use of coupling fluids, such as oil.

Customer should pay attention to magnet attaching on the machine. The shock could overload the sensor and destroy the electronic.

Ordering information

To order, specify part number, options and suffix :

221.01- AA - BB

AA : Sensor thread

06 - M6x1

16 - 1/4" 28 UNF

BB : Diameter

25 - 25 mm

Stocked models :

221.01-06-25 / 221.01-16-25

Ordering example

221.01-06-25 Curved magnet, M6

Specifications

Dynamic

Frequency response..... 10% : DC to 2.5 kHz
..... see fig 4a

Environmental

Temperature-55°C to 160 °C (-67°F to 320°F)

Physical

Dimensions See outline drawing Fig 1a

Weight ~75 gr (~ 2.64 Oz)

MaterialStainless steel

Magnet high temperature rare earth magnet
pull force 23 kg (50 Lbs)

Accessories

Magnet targets..... model 208

Competitors cross reference list

Wilcoxon B3 / CTC online MH103-1B - MH136-1A / PCB 080A121 (080A120) /

AMPO EMID 22 (very low pull force)



Model 221.01-06-25

Outline drawing

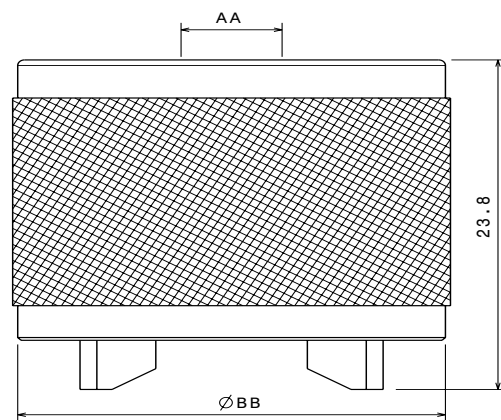

Fig 1a

Mounting drawing

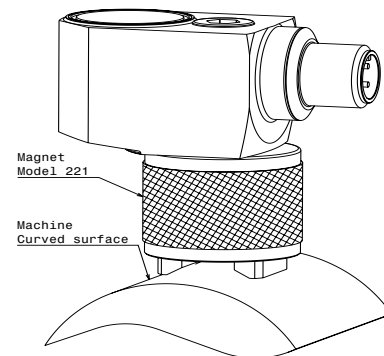

Fig 2a

Typical frequency response

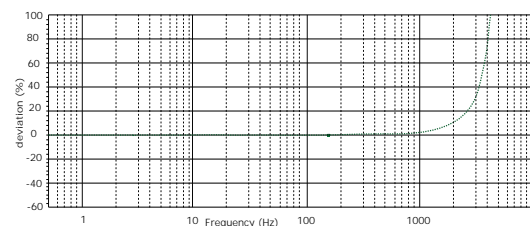

Fig 4a